

DOLAV Ace Box Pallet

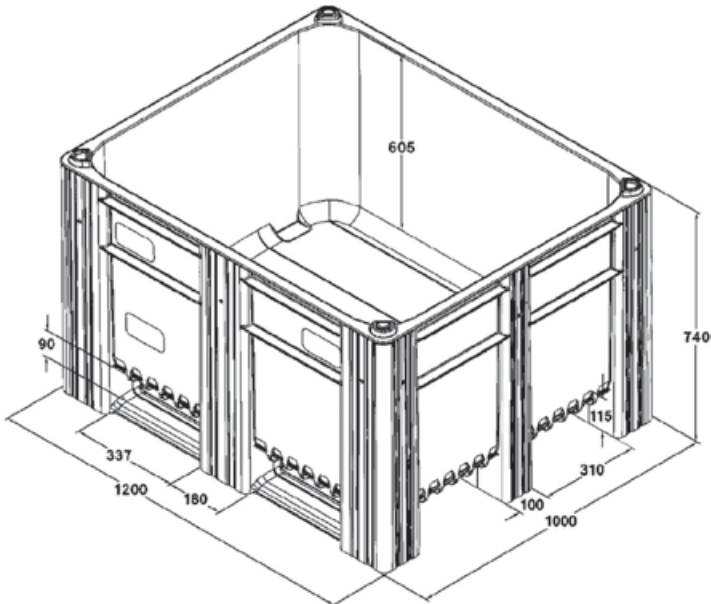

Specifically designed for hygiene

- Low lifetime cost
- Three integral runners - cannot pull out or conceal dirt traps
- Easily cleaned with no hidden crevices
- Manufactured in food-grade HDPE - easily repaired with hot-air welding
- Hygienic design - certified by Campden BRI
- Withstands abuse - TÜV SÜD tested



SOLID /PERFORATED - 3-runners	
External Dimensions (mm)	1200 x 1000 x 740
Internal Dimensions (mm)	1128 x 928 x 605
Volume (litre)	620
Material	HDPE
Temperature Range	-40°C to +60°C
Tare Weight (kg)	36.5
Max. Load (kg)	900
Max. Stacking Load (kg)	5,000
Dolav Colours	Light grey, blue, red, yellow, green
Lids Available	Light grey, blue, red, yellow, green, white

NOTES: Data refers to temperature of 23°C.
Tare weight tolerance is ±0.5kg.
Maximum stacking load refers to vertical loading when the load in each box pallet does not exceed 500kg.



DOLAV UK LIMITED, Neaton Business Park, Norwich Road, Watton, Norfolk IP25 6JB
Office: 01953 889422 • Fax: 0871 2668827 • Web: www.uk.dolav-news.com

DOLAV IRELAND, 2 Broadmeadows Road, Swords, Co. Dublin
Office: +353(0) 1 8402354 • Mob: +353(0) 87 2578321 • Web: www.dolav-ireland.ie

